

CEPH STORAGE FOR OPENSTACK PRIVATE CLOUD

Highly scalable, open-source block and object storage, designed for enterprise workloads.

Rackspace provides Ceph storage as part of your Rackspace OpenStack® Private Cloud or as a standalone deployment. Ceph, an open-source storage platform, provides highly scalable block and object storage in the same distributed cluster. Running on commodity hardware, it eliminates the costs of expensive, proprietary storage hardware. Built with enterprise usage in mind, Ceph can support workloads scaling to hundreds of petabytes, such as artificial intelligence, data lakes and large object repositories.

WHY RACKSPACE FOR CEPH STORAGE?

Rackspace goes beyond Ceph setup and configuration by assuming responsibility for the challenges and complexity of "Day 2" operations and support, including monitoring, upgrading and expanding clusters. Plus, Ceph experts will help you solve your block and object storage needs, from taking care of standalone object stores to integrating with your OpenStack private cloud – and everything in between. Whether you need the community or Red Hat® edition of Ceph, Rackspace can meet your complex and demanding storage requirements.

KEY BENEFITS

Easy Adoption: Moving to software-defined storage platforms can be complicated and risky. With a partner like Rackspace, your path to SDS adoption can be smooth and your business can focus on obtaining immediate value. Ceph supports block and object storage on the same cluster, so you don't need to administer separate storage services with separate APIs and technologies. Additionally, the RESTful interface supports both OpenStack Swift and Amazon Simple Storage Service (S3), simplifying data migration.

Compelling Economics: Ceph runs on commodity hardware, which eliminates the need for expensive, specialized hardware. And, with Rackspace OpenStack Private Cloud, you have a choice of capex or opex models, as well as pay-as-you-go options to help control costs and improve your financial transparency.

High Availability and Durability, with Improved Performance: Erasure coding adds resiliency and durability to improve your data availability, and the addition of the BlueStore backend for Ceph provides full check summing, built-in compression and, in some circumstances, write speeds twice as fast as the previous Ceph backend, FileStore. Finally, when OpenStack Nova virtual machines are backed by Ceph, your virtual instances can move to another host for improved resiliency and high availability.

Safety & Security: Security features such as LDAP and Active Directory integration as well as encryption-at-rest can help to limit access to sensitive data.

EXPERTISE

No one knows open-source infrastructure operations better than Rackspace:

Operational Expertise: Rackspace has over 1 billion server-hours of open source cloud operation and only delivers features that are fully tested and validated to meet your needs and scale.

Unmatched Experience: Rackspace knows how to operate Ceph with OpenStack at enterprise scale.

Reduced Complexity: Rackspace eliminates the complexity of adoption, upgrades and updates, helping to ensure that your storage remains current and available to support your business.

TRUST RACKSPACE

- Leader in the 2017 Forrester Hosted Private Cloud Wave
- Leader in Industrialized Private Cloud in the 2017 Gartner Magic Quadrant for Cloud Infrastructure as a Service, Worldwide
- Hosting provider for more than half of the Fortune 100
- 3,000+ cloud experts available 24x7x365
- 20+ years of hosting experience
- Customers in 150+ countries
- Over 1 billion server-hours of open source cloud operation
- Industry-leading service level agreements

CONTACT US

RPC@rackspace.com

www.rackspace.com/openstack/private



Deep OpenStack Knowledge: Rackspace created OpenStack with NASA in 2010 and is one of the all-time leading code contributors.

SERVICE

Rackspace delivers Fanatical Support® for the world's leading clouds – it's the specialized expertise and 24x7x365, results-obsessed customer service that's been a part of its DNA since 1999. When you choose Ceph storage for OpenStack Private Cloud, you get:

Monitoring and Maintenance: Proactive monitoring and maintenance of your Ceph deployment, including installation, configuration, patching, updating, troubleshooting and capacity planning

24x7x365 Access: Around-the-clock access to OpenStack and Ceph engineers

Dedicated Account Manager: A go-to resource to help you continually update and improve your Ceph environment as your workload needs evolve

Professional Services: Resources to help you accelerate adoption and modernize, automate and optimize your Ceph environment

REFERENCE ARCHITECTURE

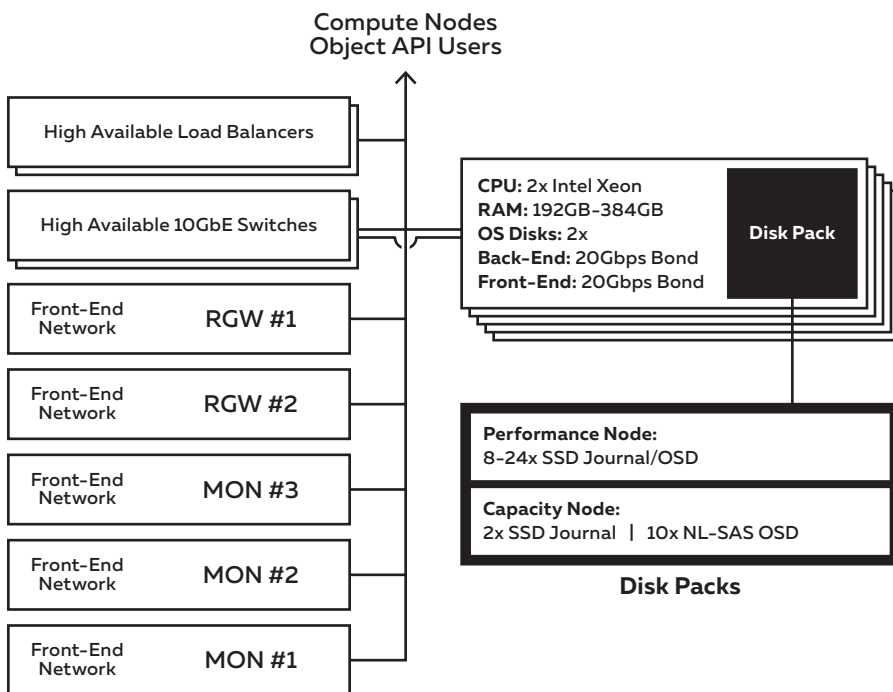

CONTACT US

RPC@rackspace.com
www.rackspace.com/openstack/private

